



(11) **EP 1 803 869 B1**

(12) **EUROPEAN PATENT SPECIFICATION**

(45) Date of publication and mention of the grant of the patent:
14.01.2009 Bulletin 2009/03

(51) Int Cl.:
E04F 15/10^(2006.01)

(21) Application number: **06126194.7**

(22) Date of filing: **14.12.2006**

(54) **Floor plank being a laminate of two layers of flexible plastic sheet material laminated together in offset relationship**

Bodenbelagsplanke aus zwei Schichten flexiblen Kunststoffbahnen, die zueinander versetzt zusammengeklebt sind

Planche de revêtement de sol avec deux couches en plastique flexible qui sont laminés avec un décalage

(84) Designated Contracting States:
AT BE BG CH CY CZ DE DK EE ES FI FR GB GR HU IE IS IT LI LT LU LV MC NL PL PT RO SE SI SK TR

(30) Priority: **29.12.2005 US 321015**

(43) Date of publication of application:
04.07.2007 Bulletin 2007/27

(73) Proprietor: **Tru Woods Limited Causeway Bay, Hong Kong (CN)**

(72) Inventors:
• **Stone, Norman Harrison, NY 10528 (US)**

• **Zhengxing, Song**
215600 Jiangsu Province (CN)

(74) Representative: **Austin, Hedley William et al Chapman Molony Cardiff Business Technology Centre Senghennydd Road Cardiff CF24 4AY (GB)**

(56) References cited:
WO-A-99/49152 CA-A1- 2 545 319
DE-A1- 1 914 705 DE-A1- 3 031 036
DE-U1- 20 108 723 DE-U1- 20 307 987
GB-A- 1 308 011

EP 1 803 869 B1

Note: Within nine months of the publication of the mention of the grant of the European patent in the European Patent Bulletin, any person may give notice to the European Patent Office of opposition to that patent, in accordance with the Implementing Regulations. Notice of opposition shall not be deemed to have been filed until the opposition fee has been paid. (Art. 99(1) European Patent Convention).

Description

[0001] This invention relates to floor covering in the nature of planks.

[0002] US patent 1,978,075 discloses a woodblock flooring which has a tongue and groove engagement system for sacrament of similar blocks in side-by-side relationship. Since the blocks are formed of wood, they are generally rigid and inflexible, and do not easily conform to surface contours and surface irregularities of a floor base. The woodblocks are also secured to a floor base using mastic or nailing.

[0003] US patent 2,914,815 discloses an interlocked flooring system wherein individual blocks have offset base members formed of plywood. The plywood base members are laminated to the blocks and permit securement of similar blocks in side-by-side arrangement. The plywood base members are also generally rigid and inflexible. Thus the blocks do not easily conform to surface contours and surface irregularities of a floor base.

[0004] US patent 3,554,850 shows parquet flooring with projecting parts for side-by-side securement of similar parquet sections. The parquet flooring is generally rigid and inflexible and thus cannot easily conform to surface contours and surface irregularities of a floor base.

[0005] DE-20108723U1 discloses a floor tile of flexible plastics sheet material having a first rectangular (upper) layer with four side edges, an upper surface and a lower surface, and a second rectangular (lower) layer with four side edges, an upper surface and a lower surface. In one embodiment, the first and second layers are laminated together in offset relationship with the lower surface of the first (upper) layer contacting the upper surface of the second (lower) layer. This offset relationship defines a first offset margin along one edge of the upper layer and a corresponding offset margin along an edge of the lower layer.

[0006] DE-1914705-A1 and DE 3031036 also disclose floor tiles with upper and lower layers which are offset relative to one another so as to form overlapping edge portions. Neither these nor DE-20108723U1 concern planks; neither do they disclose or suggest a floor covering with upper and lower plastics layers having a flexibility that permits the floor covering to conform to surface contours of the floor base upon which the floor covering is laid.

[0007] It is an object of the invention to provide floor coverings in the form of planks that can be installed on a floor base without being bonded to the floor base, and that can be securable to similar adjacent floor planks on a floor base and be conformable to surface contours and surface irregularities of the floor base. This object is provided according to the invention by the features defined in claim 1.

[0008] The floor covering according to the invention comprises

- a) a first polygonal layer of flexible plastics sheet

material having a top surface and a lower surface, b) a second polygonal layer having an upper surface and an undersurface, the first and second layers being laminated together in offset relationship, with the lower surface of the first layer contacting the upper surface of the second layer, in which the offset lamination of the first and second layers defines an offset marginal portion of the first layer and an offset marginal portion of the second layer, the marginal portion of the first layer extending beyond at least one of the side edges of the second layer, and the marginal portion of the second layer extending beyond at least one of the side edges of the first layer.

[0009] According to the invention, the floor covering is in the form of a floor plank,

the top surface of the first layer has a design pattern thereon constituting the top surface of the floor plank, the first and second layers have respective predetermined thicknesses to enable the laminate of the first and second layers to have flexibility that permits the laminate to conform to surface contours of a floor base upon which the floor file is laid,

the second layer (16, 18) comprises flexible plastics sheet material and has a predetermined yieldability to surface irregularities of a floor base upon which the floor tile is laid, such that the second layer, when lying in flat contact on the floor base can conform to surface irregularities of the floor base, and

the marginal portions of each of the first and second layers have an exposed adhesive coating (64, 66).

[0010] The floor plank preferably includes a third polygonal layer, this being of flexible foam material and bonded to the lower surface of the second layer and being co-extensive with the second layer such that the second and third layers have a common periphery, the foam material of the third layer having a predetermined thickness and the abovementioned yieldability.

[0011] The floor plank according to the invention may advantageously be packaged in an assembly together with one continuous strip of flexible releasable material is provided to cover the exposed adhesive coated surfaces of both of the offset marginal portions by contacting a first portion of the releasable cover material against the adhesive coating of one offset marginal portion, a second portion of the releasable cover material is contacted on the adhesive coated surface of the other offset marginal portion.

[0012] Further preferred features of the present invention are defined in the accompanying claims and described in the following description. In particular, it is preferred that the polygonal shapes are congruent rectangles.

[0013] Preferably, the marginal portion of the first layer extends beyond two intersecting side edges of the second layer such that the marginal portion is substantially L-shaped.

[0014] It is preferred that the offset marginal portion of

the second layer extends beyond two intersecting side edges of said first layer such that said second offset marginal portion is substantially L-shaped.

[0015] The first and second layers are preferably of synthetic plastics material, such as a vinyl material (typically polyvinyl chloride). The adhesive coating is preferably of a styrene-isoprene-styrene elastomer.

[0016] The upper surface of the first layer preferably has thereon a wood grain design resembling natural wood.

[0017] Preferably, the plank includes an underlayer of flexible fibrous sheet material (such as fibre glass) bonded between the first and second layers, said underlayer having a polygonal shape and being coextensive with said first layer such that said first layer and said underlayer have a common periphery.

[0018] Further preferred embodiments of the invention will now be described, by way of example only, with reference to the accompanying drawings, in which corresponding reference numbers indicate corresponding parts throughout the several views of the drawings. In the drawings:

Fig. 1 is a perspective view of a floor plank according to one embodiment of the present invention;

Fig. 2 is a perspective view of an assembly pattern thereof;

Fig. 3 is a sectional view taken on the line 3-3 of Fig. 2;

Fig. 4 is a sectional view taken on the line 4-4 of Fig. 2;

Fig. 5 is a sectional view thereof on a floor base;

Fig. 6 is a perspective view showing the flexibility characteristics of the floor plank;

Fig. 7 is a perspective view of a plank according to another embodiment of the invention;

Fig. 8 is a perspective view of an assembly pattern thereof;

Fig. 9 is a sectional view taken on the line 9-9 of Fig. 8;

Fig. 10 is a sectional view taken on the line 10-10 of Fig. 8;

Fig. 11 is a sectional view thereof on a floor base;

Figs. 12 to 14 are perspective views of of the floor plank another embodiment of the invention, before, during and after installation of the floor plank;

Fig. 15 is a plan view of the releasable cover member packaging device; and

Fig. 16 is a perspective view of a floor plank incorporating a further embodiment of the invention.

[0019] Referring to the drawings, a floor plank incorporating a preferred embodiment of the invention is generally indicated by the reference number 10 in Fig. 1. The floor plank 10 is a laminate of a top layer 14 of flexible plastics sheet material, a middle layer 16 of flexible plastics sheet material and a bottom layer 18 of flexible foam material. All of the layers 14, 16 and 18 are of identical polygonal size and shape, preferably rectangular.

[0020] The top layer 14 and the middle layer 16 are preferably formed of synthetic plastics material, preferably

by a vinyl plastics material such as polyvinyl chloride sheeting material. An upper surface 24 of the top layer 14 is provided with a design such as a synthetic wood grain design (Fig. 6) that resembles natural wood. The bottom layer 18 is formed of a soft flexible foam material such as polyurethane foam.

[0021] The middle plastics layer 16 and bottom foam layer 18 are laminated together such that they are coextensive and have a common periphery. However the top plastics layer 14 is laminated to the middle plastics layer 16 such that the top layer 14 is offset from the middle layer 16.

[0022] In the offset layer arrangement, a long edge 26 (Fig. 1) of the top layer 14 extends an offset amount "a" beyond a long edge 32 of the middle layer 16 and a short edge 34 of the top layer 14 extends an offset amount "a" beyond a short edge 40 of the middle layer 16 to define an offset L-shaped marginal section 42 of the top layer 14.

[0023] Also in the offset layer arrangement, a long edge 46 (Fig. 1) of the middle layer 16 extends an offset amount "a" beyond a long edge 48 of the top layer 14, and a short edge 50 of the middle layer 16 extends an offset amount "a" beyond a short edge 56 of the top layer 14 to define an offset L-shaped marginal section 58 of the middle layer 16. The L-shaped marginal section 42 of the top layer 14 and the L-shaped marginal section 58 of the middle layer 16 are of identical size and shape.

[0024] A suitable bonding or adhesive composition for laminating the top plastics layer 14 and middle plastics layer 16 together has the following components, the amounts of which are approximate:

- a) 35% SIS (styrene-isoprene-styrene elastomer)
- b) 54.5% petroleum resin
- c) 10% mineral oil
- d) 0.05% oxidation resistant BHT (2,6-di-tert-butyl-p-cresol)

[0025] The bonding material for the layers 14 and 16 is provided on a lower surface 64 (Fig. 3) of the top plastics layer 14 and on an upper surface 66 of the middle plastics layer 16.

[0026] The same bonding material applied to the lower surface 64 and the upper surface 66 for laminating top plastics layer 14 and the middle plastics layer 16 can also be used for laminating the bottom foam layer 18 to the middle plastics layer 16.

[0027] The L-shaped marginal section 42 has a downwardly directed adhesive surface 72 (Fig. 1) that is part of the lower surface 64 (Fig. 3) of the top layer 14 and the L-shaped marginal section 58 has an upwardly directed adhesive surface 74 (Fig. 1) that is part of the upper surface 66 (Fig. 3) of the middle layer 16. The adhesive on the exposed adhesive surfaces 72 and 74 is the bonding material used for laminating the top plastics layer 14 and the middle plastics layer 16 together.

[0028] Although the dimensions of the floor plank 10 are a matter of choice, a suitable size for the top layer

14, the middle layer 16 and the bottom layer 18 can be, for example, 6 inches (about 15 cm) by 48 inches (about 145 cm)

[0029] The thickness of the top layer 14 can be, for example, approximately 2.0 mm and the thickness of the middle layer 16 can be, for example, approximately 2.5 mm. The thickness of the bottom foam layer 18 can be, for example, approximately 3 mm. The marginal offset "a" can be, for example, approximately $\frac{3}{4}$ of an inch (about 1.9 cm). Larger offsets would be provided for larger panels.

[0030] The floor plank 10 is sufficiently flexible as schematically indicated in Fig. 6, to conform to typical variations in surface contour of a floor base 102 (Fig. 5) upon which the floor plank 10 is laid. In addition, the flexible foam material of the bottom layer 18 is yieldable to small bumps and other imperfections in the floor base 102 generally referred to as surface irregularities. The bottom foam layer 18 thus enables the floor plank 10 to conform to such surface irregularities and lie flat on the floor base 102.

[0031] During installation of the floor planks 10 in side-by-side and end-to-end relationship, the downwardly directed adhesive surface 72

[0032] The L-shaped marginal section 42 (Fig 1) of the top layer 14 is positioned so as to engage the upwardly directed adhesive surface 74 of the L-shaped marginal section 58 of the middle layer 16, to form the assembly 80 of the floor planks 10 as shown in Fig. 2. When placing two of the planks 10 together, one plank 10 can be angled at approximately 45° (not shown) relative to the floor base 102 and onto the corresponding upwardly facing adhesive surface 74 (Fig. 1) of an adjacent floor plank 10.

[0033] The floor plank assembly pattern 80 (Fig. 2) is but one example of numerous possible plank patterns known in the art.

[0034] The floor planks 10 can be installed on the floor base 102 (Fig. 5) without mastic or an adhesive coating on the floor base 102, and without mastic or adhesive on an undersurface 88 (Fig. 3) of the bottom foam layer 18. Thus during installation, the floor planks 10 can be placed on a dry floor base surface 102 for easy shifting to any selected position, thereby facilitating installation of the floor planks 10 in any desired pattern.

[0035] Preferably the installation of floor planks 10 should start in a corner of a room (not shown) and proceed outwardly therefrom. An expansion gap of $\frac{1}{4}$ inch or about 0.6 cm, for example, from each wall is generally suitable for most installations. The expansion gap is usually covered by moulding. It has also been found helpful to provide double faced tape on the first row of floor planks 10 to help maintain the first row in place during the positioning of adjacent floor planks 10.

[0036] The top layer 14, the middle layer 16 and the bottom layer 18 of the floor plank 10 are provided with an overall thickness that enables the floor plank 10 to be easily cut with a utility knife, if trimming is needed. Ease of trimming the floor plank 10, as well as the mastic-free

placement of the planks 10 on a floor base, 102 make it convenient for a do-it-yourselfer to instal the floor planks 10..

[0037] Another embodiment of the floor plank is generally indicated by the reference number 100 in Fig. 7. The floor plank 100 is a laminate of the top layer 14 and the middle layer 16 of the floor plank 10, with the bottom foam layer 18 being omitted. The layers 14 and 16 are laminated together with marginal offsets "a" as previously described with respect to the floor plank 10.

[0038] The floor plank 100 thus includes identical L-shaped marginal sections 42 and 58 with identical offsets "a".

[0039] In installing the floor plank 100 on a floor base 102 (Fig. 11), a lower surface 104 of the layer 16 can be free of any mastic or adhesive covering and placed in direct contact with the floor base 102. The floor base 102 can also remain free of any mastic or adhesive covering. Installation of the floor planks 100 in a plank assembly pattern 110 (Fig. 8) is accomplished in a manner similar to that previously described for the installation of the floor plank 10 in the plank assembly pattern 80 (Fig. 2).

[0040] The lower surface 104 (Figs. 7 and 8) of the layer 16 which contacts the floor base 102 (Fig. 11) is yieldable to surface irregularities of the floor base 102 and thus enables the floor plank 100 to conform to such surface irregularities and lie flat on the floor base 102, as shown in Fig. 11.

[0041] A packaging system for the floor plank is generally indicated by the reference number 120 in Fig. 12. The packaging system 120 will be described in connection with the floor plank 10 but is equally applicable to the floor plank 100.

[0042] The packaging system 120 includes a one-piece releasable cover member 122 (Fig. 15) preferably of generally rectangular shape and formed of a suitable flexible release material, such as release paper or releasable plastics, that is of a paper thin gauge. A suitable release material is silicone coated paper or equivalent release material.

[0043] The releasable cover member 122 (Fig. 15) has a rectangular outer periphery defined by opposite long side portions 128, 130 and opposite short side portions 136 and 138. The releasable cover member 122 also has a rectangular inner periphery defined by opposite long side portions 144, 146 and opposite short side portions 152 and 154. The distance between the outer peripheral side portions 128, 130, 136 and 138 and the corresponding inner peripheral side portions 144, 146, 152 and 154 is approximately equivalent to the marginal offset "a" of the L-shaped marginal sections 42 and 58.

[0044] The length of the outer long sides 128 and 130 of the releasable cover member 122 (Fig. 15) is at least equal to the length of any of the long edges 26, 32, 46 and 48 (Fig. 1) of the layers 14 and 16 plus the marginal offset "a" of the L-shaped marginal sections 42 and 58. The length of the outer short sides 136 and 138 (Fig. 15) of the releasable cover member 122 is at least equal to

the length of any of the short edges 34, 40, 50 and 56 (Fig. 1) of the layers 14 and 16 plus the marginal offset "a" of the L-shaped marginal sections 42 and 58.

[0045] The length of the inner long sides 144 and 146 of the releasable cover member 122 (Fig. 15) is approximately equivalent to the length of any of the long edges 26, 32, 46 and 48 (Fig. 1) of the layers 14 and 16 minus the marginal offset "a". The length of the inner short sides 152 and 154 of the releasable cover member 122 (Fig. 15) is approximately equivalent to the length of any of the outer short edges 34, 40, 50, and 56 (Fig. 1) of the layers 14, 16 and 18 minus the marginal offset "a".

[0046] The following reference identifications can be made for the plank 10 and the releasable cover member 122;

A = the length of any of the long edges 26, 32, 46 and 48 of the layers 14 and 16

B = the length of any of the short edges 34, 40, 50 and 56 of the layers 14 and 16

C = the length of any of the outer long sides 128 and 130 of the releasable cover member 122

D = the length of any of the outer short sides 136 and 138 of the releasable cover member 122

E = the length of any of the inner long sides 144 and 146 of the releasable cover member 122

F = the length of any of the inner short sides 152 and 154 of the releasable cover member 122

a = the marginal offset of the L-shaped marginal portions 42 and 58

[0047] The following relationships between the plank 10 and the releasable cover member 122 can be expressed in terms of the previous reference identifications as follows,

$$C = A + a$$

$$D = B + a$$

$$E = A - a$$

$$F = B - a$$

[0048] The packaging device 122 is assembled to the floor plank 10 in the manner shown in Figs. 12, 13 and 14. Thus two intersecting sides 160 and 162 (Figs. 12 and 15) of the releasable cover member 122 are placed against the downwardly exposed adhesive surface 72 (Figs. 1 and 12) of the L-shaped marginal section 42 as shown in Fig. 13, and the remaining two intersecting sides 168, 170 (Figs. 12 and 15) of the releasable cover member 122 are placed against the upward exposed adhesive

surface 74 (Fig. 1) of the L-shaped marginal section 58.

[0049] Under this arrangement the inner long side portion 144 of the releasable cover member 122 is placed against the long edge 32 of the middle layer 16 and the inner short side portion 154 of the releasable cover member 122 is placed against the short edge 40 of the middle layer 16. The sides 160 and 162 of the releasable cover member 122 can thus contact and cover the downwardly exposed adhesive surface 72 of the L-shaped marginal portion 42, as shown in Fig. 13.

[0050] After the sides 160 and 162 of the releasable cover member 122 have been positioned against the downwardly exposed adhesive surface 72 of the L-shaped marginal section 42 the intersecting sides 168 and 170 of the device 122 are moved forward and against the upwardly exposed adhesive surface 74 of the L-shaped marginal section 58 as shown in Figs. 13 and 14. The inner long side portion 146 of the releasable cover member 122 (Fig. 12) is thus placed against the long edge portion 48 of the top layer 14 and the inner short side portion 152 of the releasable cover member 122 is placed against the short edge portion 56 of the top layer 14.

[0051] The releasable cover member 122 can be stretched slightly, if needed, to accomplish the positioning of the sides 160 and 162 of the releasable cover member 122 against the downwardly exposed adhesive surface 72 and the positioning of the sides 168 and 170 of the releasable cover member 122 against the upwardly exposed adhesive surface 74.

[0052] In this manner the one piece releasable cover member 122, preferably of closed rectangular periphery, covers all the exposed adhesive surfaces of both L-shaped marginal sections 42 and 58 even though the panel 10 includes one L-shaped marginal section 42 with a downwardly exposed adhesive surface 72 (Fig. 1) and the other L-shaped marginal section 58 has an upwardly exposed adhesive surface 74.

[0053] Thus all exposed adhesive surfaces of the floor plank 10, even though they face in opposite directions at different peripheral sections of the plank 10 can be covered and protected with a one piece releasable cover member 122 until such planks are ready for installation. The releasable cover member 122 when installed on each of the planks 10 before such planks are ready for use permits the floor planks 10 to be stacked one on top of another (not shown) without one plank 10 adhering to another plank 10. The planks 10 can be stacked for packaging or for display purposes.

[0054] A further and preferred embodiment of the floor plank is generally indicated by the reference number 180 in Fig. 16.

[0055] The floor plank 180 includes all components of the floor plank 10, with the same marginal offsets as previously described, plus an underlayer 182 of flexible fibrous sheet material sandwiched between the top layer 14 and the middle layer 16. The underlayer 182 provides enhanced dimensional stability to the floor plank 180.

[0056] The top layer 14 and the underlayer 182 are coextensive and have a common periphery. Preferably the underlayer 182 is formed of a non-woven glass fibre material such as fibre glass, having a thickness of approximately 0.2 mm.

[0057] The top layer 14 and the underlayer 182 are bonded to the middle layer 16 in offset relationship such that floor plank 180 includes the identical L-shaped marginal sections 42 and 58 with identical offsets "a" as previously described for the floor plank 10. The marginal section 42 has the downwardly exposed adhesive surface 72 on the underlayer 182 and the marginal section 58 has the upwardly exposed adhesive surface 74 on the middle layer 16.

[0058] The adhesive on the exposed surfaces 72 and 74 is the same adhesive used in the floor plank 10 to bond the top layer 14 to the middle layer 16. Thus the same adhesive is used to bond the underlayer 182 to the top layer 14 and to the middle layer 16, and to bond the middle layer 16 to the bottom layer 18.

[0059] The floor plank 180 is installed on a floor in a manner similar to that previously described for the floor plank 10.

Claims

1. A floor covering (10) comprising,

- a) a first polygonal layer (14) of flexible plastics sheet material having an upper surfaces (24) and a lower surface (64), and
- b) a second polygonal layer (16) having an upper surface (66) and a lower surface, said first and second layers being laminated together in offset relationship, with the lower surface of the first layer contacting the upper surface of the second layer,

in which the offset lamination of said first and second layers defines a first offset marginal portion (42) of said first layer and a second offset marginal portion (58) of said second layer, said first marginal portion of said first layer extending beyond at least one of the side edges (32) of said second layer, and said second marginal portion of said second layer extending beyond at least one of the side edges (46) of said first layer, said first offset marginal portion having a first marginal lower surface (64) that is part of the lower surface of said first layer, and said second offset marginal portion has a second marginal upper surface (66) that is a part of the upper surface of said second layer, the second marginal upper surface having an exposed adhesive coating (72)

characterized in that

the covering is in the form of a floor plank, the upper surface of the first layer has a design pat-

tern thereon, the first and second layers have respective predetermined thicknesses to enable the laminate of the first and second layers to have flexibility that permits said laminate to conform to surface contours of a floor base upon which the floor plank laid, the second layer (16,18) comprises flexible plastics sheet material and has a predetermined yieldability to surface irregularities of a floor base upon which the floor plank is laid, such that said second layer, when lying in flat contact on the floor base can conform to surface irregularities of the floor base, and the first marginal lower surface also has an exposed adhesive coating (72).

2. A floor covering according to claim 1, wherein the polygonal layers are in the shape of congruent rectangles.
3. A floor covering according to claim 2 wherein the first offset marginal portion extends beyond two intersecting side edges of said second layer such that said first offset marginal portion is substantially L-shaped.
4. A floor covering according to claim 2 or 3, wherein the second offset marginal portion extends beyond two intersecting side edges of said first layer such that said second offset marginal portion is substantially L-shaped.
5. A floor covering according to any of claims 1 to 4, in which the second layer (16) includes a third layer (18) of flexible foam material, said third layer being bonded to the lower surface of the second layer and being co-extensive with said second layer such that said second and third layers have a common periphery, the foam material of said third layer having said predetermined thickness and yieldability
6. A floor covering according to any of claims 1 to 5, which further includes a one piece releasable cover member (122) for covering both the adhesive coated first marginal lower surface of said first offset marginal portion and the adhesive coated second marginal upper surface of said second offset marginal portion, said releasable cover member comprising one continuous strip of release material extending on the adhesive coated first marginal lower surface and extending on the second marginal upper surface to cover the exposed adhesive coating of said first and second offset marginal portions, whereby said one continuous strip of release material covers the exposed adhesive coated surfaces of the first and second marginal portions.
7. A method of installing floor planks on a floor base, in which a series of floor planks according to any of

claims 1 to 6 are laid with the lower surfaces on the second layer on the floor base.

Patentansprüche

1. Bodenbelag (10), der aufweist:

- a) eine erste polygonale Lage (14) aus einem flexiblen Kunststoffschichtmaterial mit einer oberen Seite (24) und einer unteren Seite (64), und
- b) eine zweite polygonale Lage (16) mit einer oberen Seite (66) und einer unteren Seite, wobei die erste und die zweite Lage in zueinander versetzter Beziehung zusammen laminiert sind, wobei die untere Seite der ersten Lage die obere Seite der zweiten Lage berührt,

wobei die versetzte Laminierung der ersten und der zweiten Lage einen ersten Versatzrandabschnitt (42) der ersten Lage und einen zweiten Versatzrandabschnitt (58) der zweiten Lage definiert, wobei der erste Randabschnitt der ersten Lage sich über wenigstens eine der Seitenkanten (32) der zweiten Lage hinaus erstreckt und der zweite Randabschnitt der zweiten Lage sich über wenigstens eine der Seitenkanten (46) der ersten Lage hinaus erstreckt, wobei der erste Versatzrandabschnitt eine erste untere Randseite (64) aufweist, die Teil der unteren Seite der ersten Lage ist, und der zweite Versatzrandabschnitt eine zweite obere Randfläche (66) aufweist, die Teil der oberen Seite der zweiten Lage ist,

wobei die zweite obere Randseite eine freiliegende Klebstoffbeschichtung (72) aufweist,

dadurch gekennzeichnet, dass

der Bodenbelag in Form einer Bodenfliese ausgebildet ist, die obere Seite der ersten Lage eine gestaltende Musterung aufweist,

die erste und die zweite Lage entsprechend vorbestimmte Dicken aufweisen, um dem Laminat aus der ersten und der zweiten Lage eine Flexibilität zu geben, die es dem Laminat gestattet, sich an Oberflächenkonturen einer Bodenbasis anzupassen, auf die die Bodenfliese gelegt wird,

die zweite Lage (16, 18) ein flexibles Kunststoffschichtmaterial enthält und eine vorbestimmte Nachgiebigkeit in Bezug auf Oberflächenunregelmäßigkeiten der Bodenbasis aufweist, auf die die Bodenfliese gelegt ist, so dass die zweite Lage, wenn sie flach auf der Bodenbasis aufliegt, sich an Oberflächenunregelmäßigkeiten der Bodenbasis anpassen kann, und

die erste untere Randseite ebenfalls eine freiliegende Klebstoffbeschichtung (72) aufweist.

2. Bodenbelag nach Anspruch 1, bei dem die polygo-

nalen Lagen die Form kongruenter Rechtecke aufweisen.

- 3. Bodenbelag nach Anspruch 2, bei dem sich der erste Versatzrandabschnitt über zwei einander schneidende Seitenkanten der zweiten Lage so erstreckt, dass der erste Versatzrandabschnitt im Wesentlichen L-förmig ist.
- 4. Bodenbelag nach Anspruch 2 oder 3, bei dem sich der zweite Versatzrandabschnitt über zwei einander schneidende Seitenkanten der ersten Lage so erstreckt, dass der zweite Versatzrandabschnitt im Wesentlichen L-förmig ist.
- 5. Bodenbelag nach Anspruch 1 bis 4, bei dem die zweite Lage (16) eine dritte Lage (18) aus einem flexiblen geschäumten Material enthält, wobei die dritte Lage mit der unteren Seite der zweiten Lage verbunden und mit der zweiten Lage deckungsgleich ausgebildet ist, so dass die zweite und die dritte Lage einen gemeinsamen Umfang aufweisen, wobei das geschäumte Material der dritten Lage die vorbestimmte Dicke und Nachgiebigkeit aufweist.
- 6. Bodenbelag nach Anspruch 1 bis 5, der weiterhin ein einstückiges ablösbares Abdeckelement (122) zum Abdecken sowohl der Klebstoff beschichteten ersten unteren Randfläche des ersten Versatzrandabschnitts als auch der Klebstoff beschichteten zweiten oberen Randfläche des zweiten Versatzrandabschnitts aufweist, wobei das ablösbare Abdeckelement einen durchgehenden Streifen ablösbares Materials umfasst, der sich auf der Klebstoff beschichteten ersten unteren Randfläche und auf der zweiten oberen Randfläche erstreckt, um die freiliegende Klebstoffbeschichtung des ersten und des zweiten Versatzrandabschnitts abzudecken, so dass der eine durchgehende Streifen von ablösbarem Material die freiliegenden Klebstoff beschichteten Flächen des ersten und zweiten Randabschnitts abdeckt.
- 7. Verfahren zum Anbringen von Bodenfliesen auf einer Bodenbasis, bei dem eine Reihe von Bodenfliesen gemäß einem der Ansprüche 1 bis 6 mit der unteren Seite der zweiten Lage auf die Bodenbasis gelegt werden.

Revendications

1. Élément de revêtement de sol (10) comprenant :

- a) une première couche polygonale (14) d'un matériau formé d'une feuille plastique flexible comprenant une surface supérieure (24) et une surface inférieure (64), et

b) une deuxième couche polygonale (16) comportant une surface supérieure (66) et une surface inférieure, lesdites première et deuxième couches étant stratifiées pour former un ensemble et étant dans une relation décalée, avec la surface inférieure de la première couche en contact avec la surface supérieure de la deuxième couche,

dans lequel la stratification décalée desdites première et deuxième couches définit une première partie marginale (42) décalée de ladite première couche, et une deuxième partie marginale (58) décalée de ladite deuxième couche, ladite première partie marginale de ladite première couche s'étendant au-delà d'au moins une des arêtes latérales, ou bords latéraux (32), de ladite deuxième couche, et ladite deuxième partie marginale de ladite deuxième couche s'étendant au-delà d'au moins une des arêtes latérales, ou bords latéraux (46), de ladite première couche,

ladite première partie marginale décalée présente une première surface inférieure marginale (64) qui fait partie de la première surface inférieure de ladite première couche, et ladite deuxième partie marginale décalée présente une deuxième surface supérieure (66) marginale qui fait partie de la deuxième surface supérieure de ladite deuxième couche, la deuxième surface supérieure marginale présentant un revêtement adhésif exposé (72),

caractérisé en ce que

l'élément de revêtement est sous forme d'une lame de parquet,

la surface supérieure de la première couche présente un graphisme

les première et deuxième couches ont respectivement des épaisseurs prédéterminées pour permettre au stratifié formé par les première et deuxième couches d'avoir une flexibilité permettant audit stratifié de s'adapter aux contours de surface que présentent les planchers sur lequel la lame de parquet est posée,

la deuxième couche (16, 18) comprend un matériau formé d'une feuille plastique flexible et présente une déformabilité prédéterminée par rapport aux irrégularités de surface du plancher sur lequel la lame de parquet est posée, de sorte que ladite deuxième couche, quand elle est posée en contact à plat sur le plancher, peut s'adapter aux irrégularités de surface du plancher, et

la première surface inférieure marginale présente également un revêtement adhésif exposé (72).

2. Élément de revêtement de sol selon la revendication 1, dans lequel les première et deuxième formes polygonales sont des rectangles en accord entre eux.
3. Élément de revêtement de sol selon la revendication

2, dans lequel la première partie marginale décalée s'étend au-delà de deux arêtes latérales qui s'entrecroisent de ladite deuxième couche, de sorte que ladite première partie marginale décalée soit sensiblement en forme de L.

4. Élément de revêtement de sol selon la revendication 2 ou 3, dans lequel la deuxième partie marginale décalée s'étend au-delà de deux arêtes latérales qui s'entrecroisent de ladite première couche, de sorte que ladite deuxième partie marginale décalée soit sensiblement en forme de L.

5. Élément de revêtement de sol selon l'une quelconque des revendications 1 à 4, dans laquelle la deuxième couche (16) comprend une troisième couche (18) de matériau alvéolaire flexible, ladite troisième couche étant collée à la surface inférieure de la deuxième couche, et étant coextensive avec ladite deuxième couche, de sorte que lesdites deuxième et troisième couches ont une périphérie commune, le matériau alvéolaire de ladite troisième couche ayant ladite épaisseur et déformabilité prédéterminées.

6. Élément de revêtement de sol selon l'une quelconque des revendications 1 à 5, comprenant en outre un élément formant couvercle détachable (122), pour recouvrir à la fois la première surface inférieure marginale revêtue d'adhésif (72) de ladite première partie marginale décalée et la deuxième surface supérieure marginale revêtue d'adhésif de ladite deuxième partie marginale décalée, ledit élément formant couvercle détachable comprenant une bande continue de matériau détachable, s'étendant sur la première surface inférieure marginale revêtue d'adhésif et s'étendant sur la deuxième surface supérieure marginale pour recouvrir le revêtement adhésif exposé desdites première et deuxième parties marginales décalées, de sorte que ladite bande continue de matériau détachable recouvre les surfaces exposées revêtues d'adhésif des première et deuxième parties marginales.

7. Procédé d'installation de lames de parquet sur un plancher, dans lequel une série de lames de parquet selon l'une quelconque des revendications 1 à 6 sont posées avec les surfaces inférieures de la deuxième couche sur le plancher.

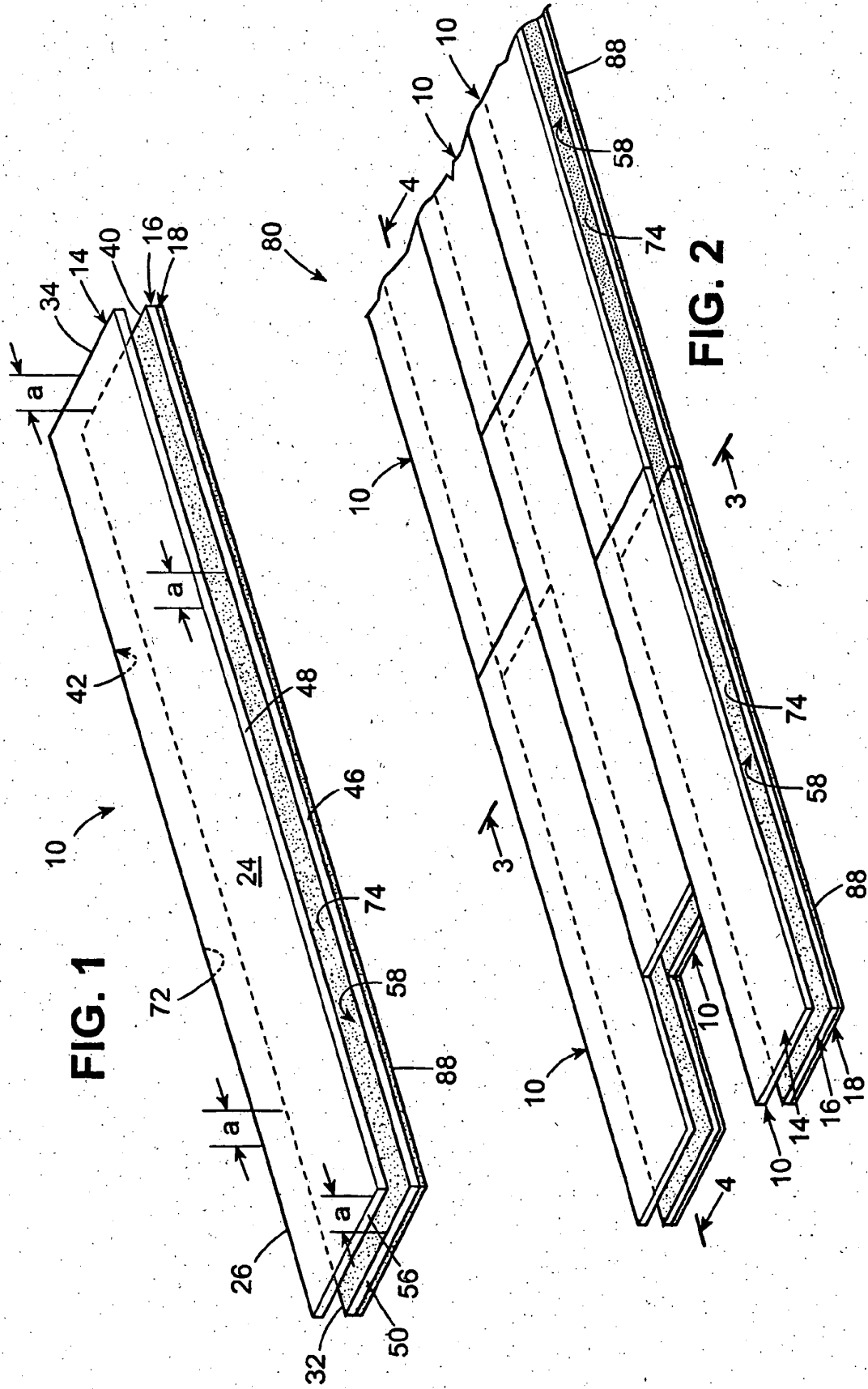

FIG. 1

FIG. 2

FIG. 3

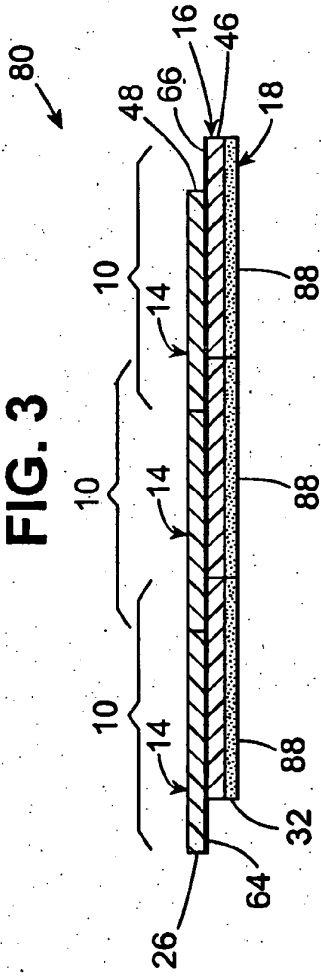

FIG. 4

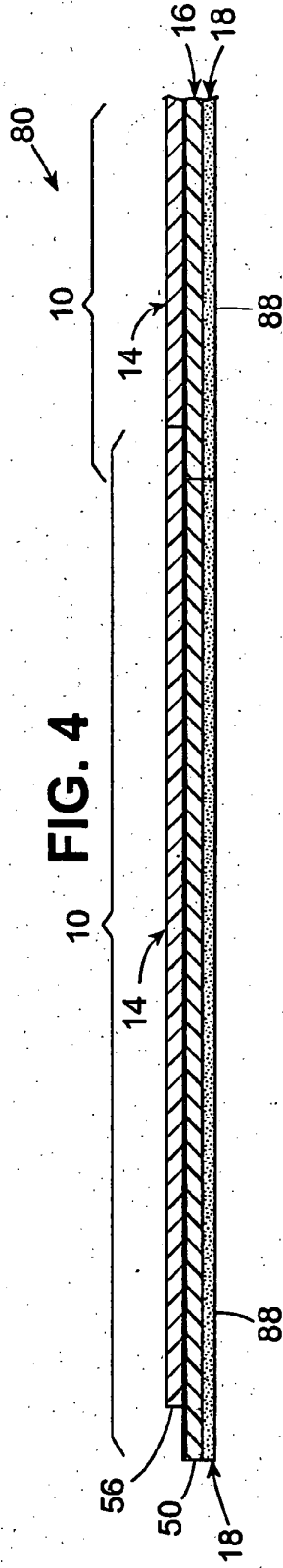
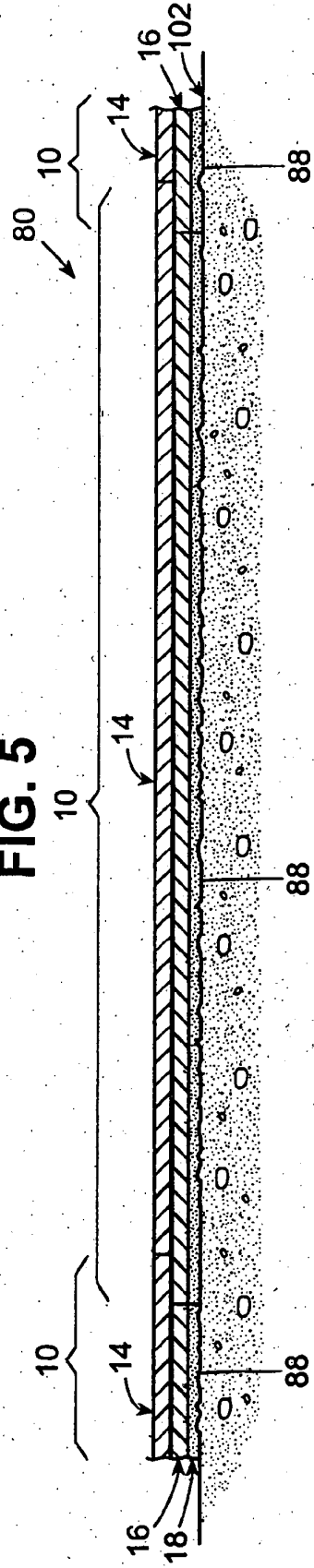
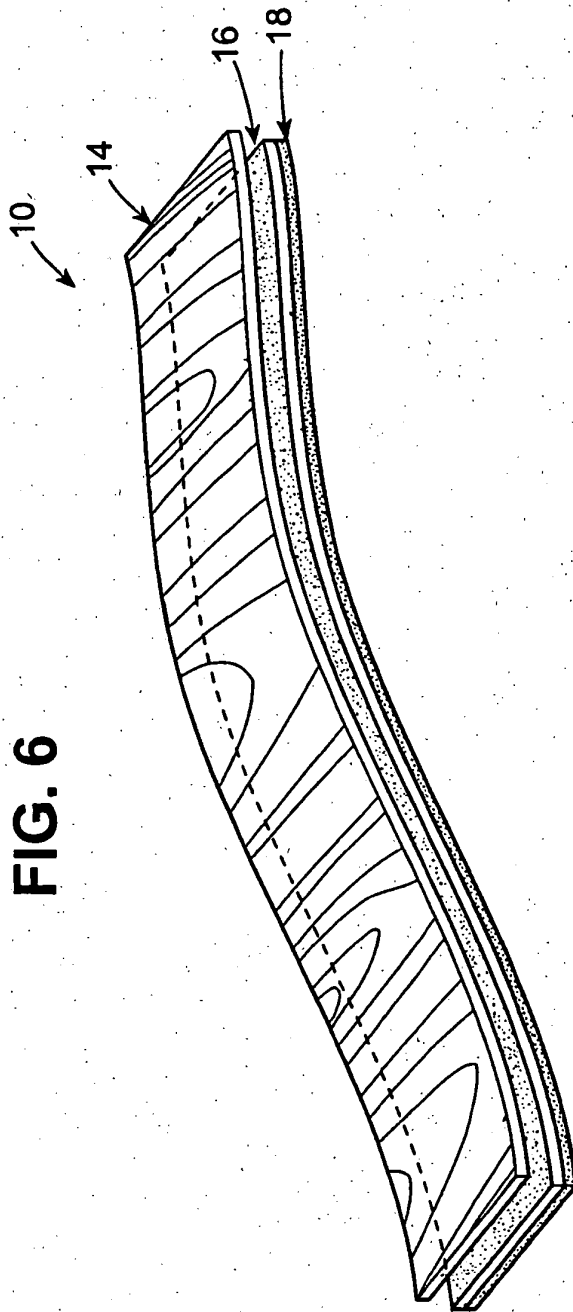

FIG. 5





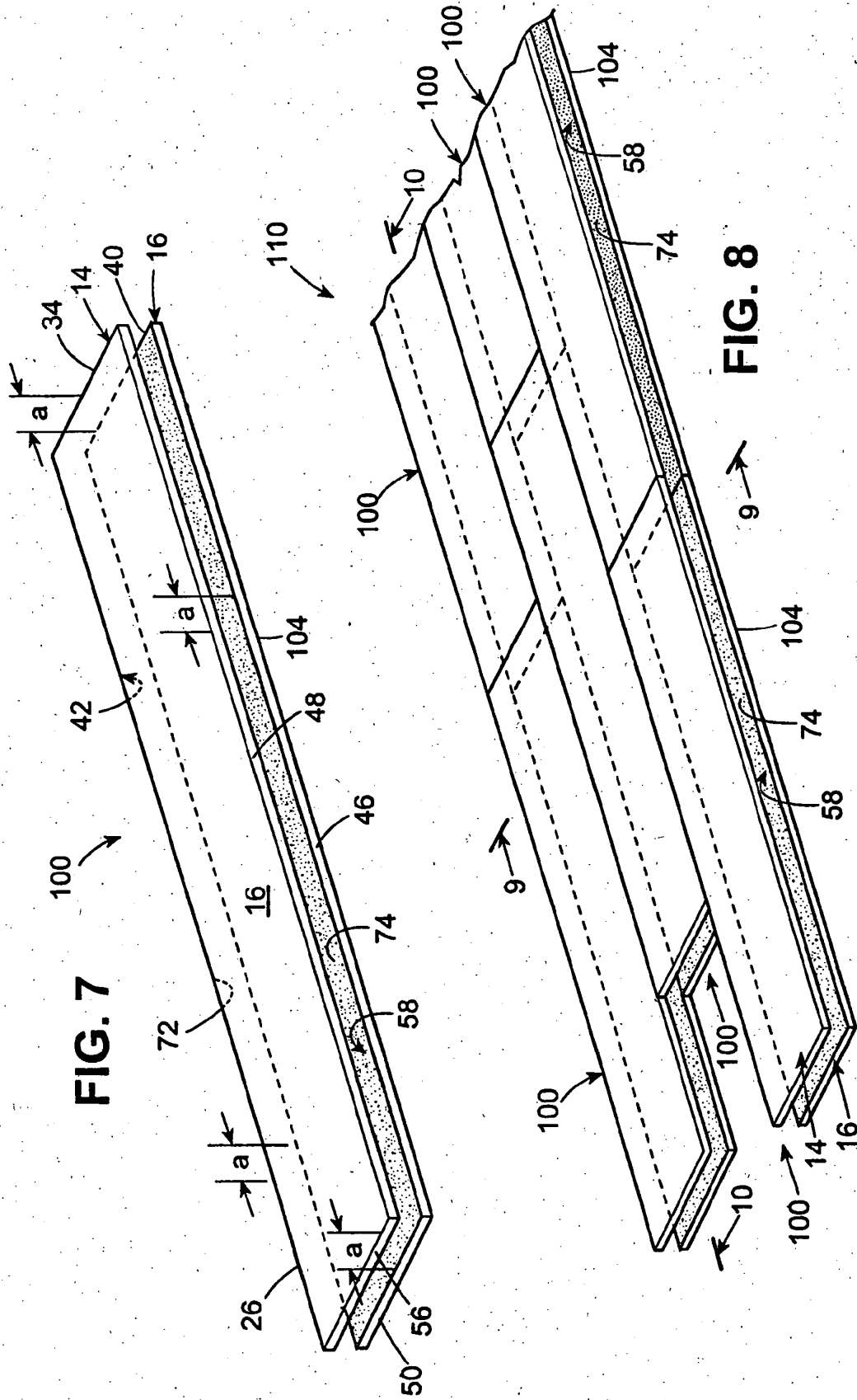

FIG. 7

FIG. 8

FIG. 9

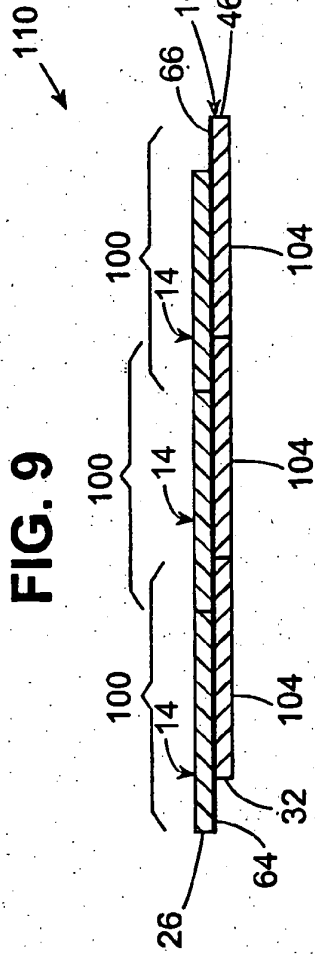

FIG. 10

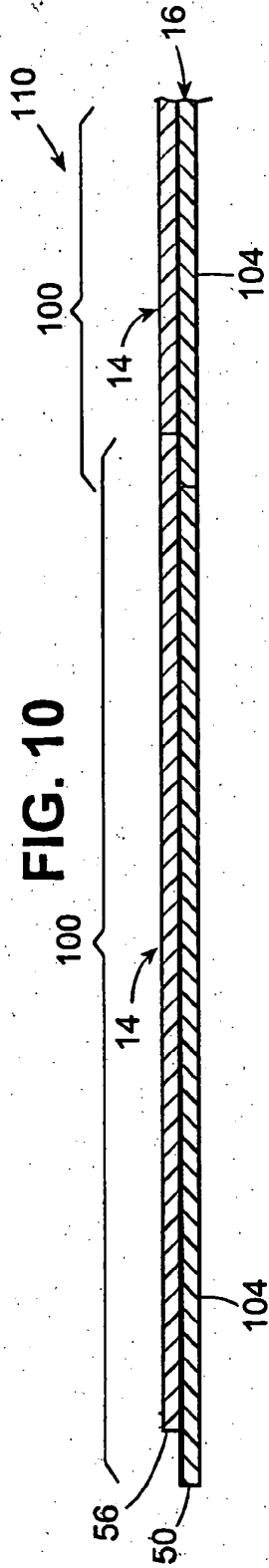
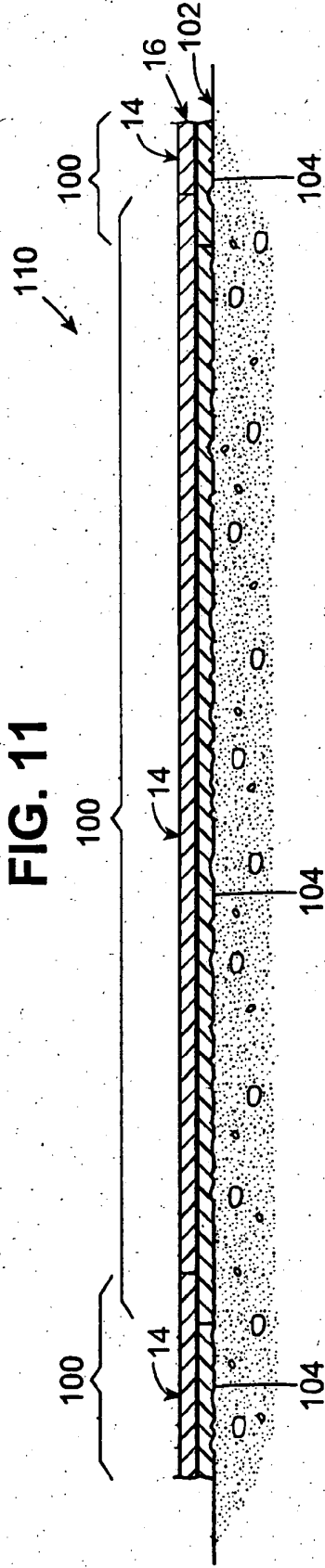

FIG. 11



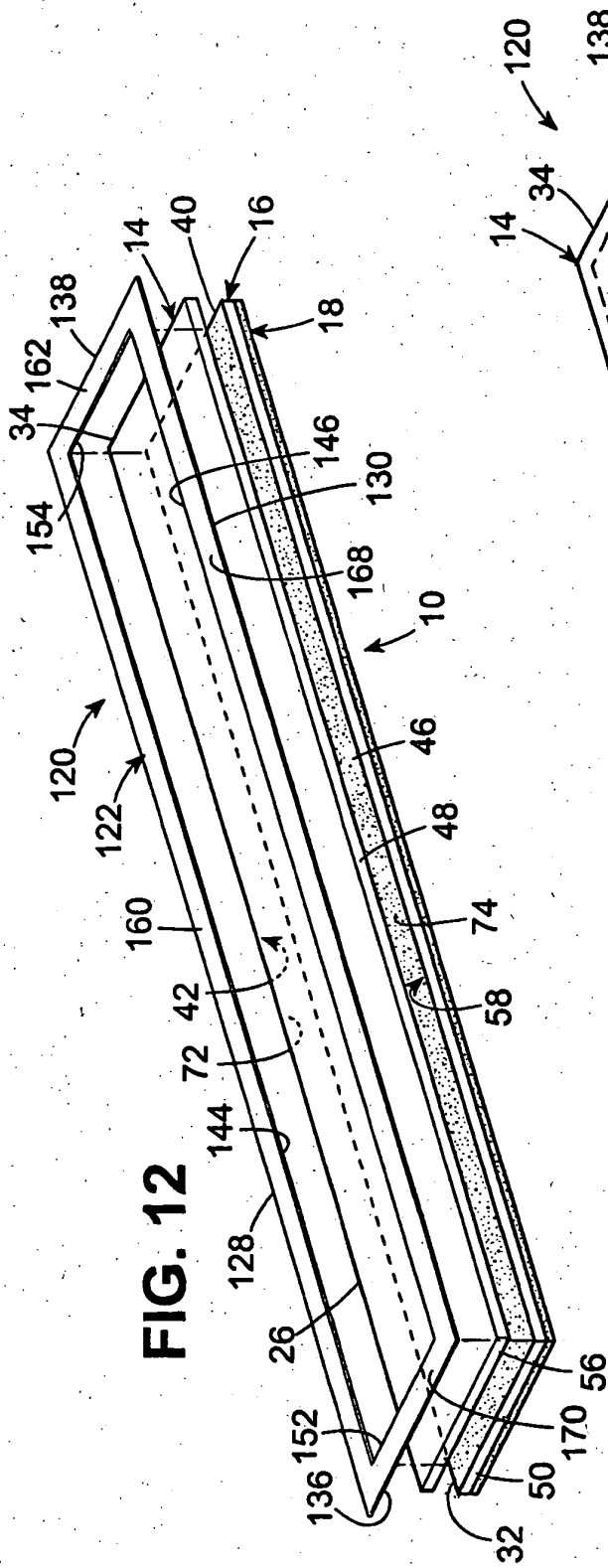

FIG. 12

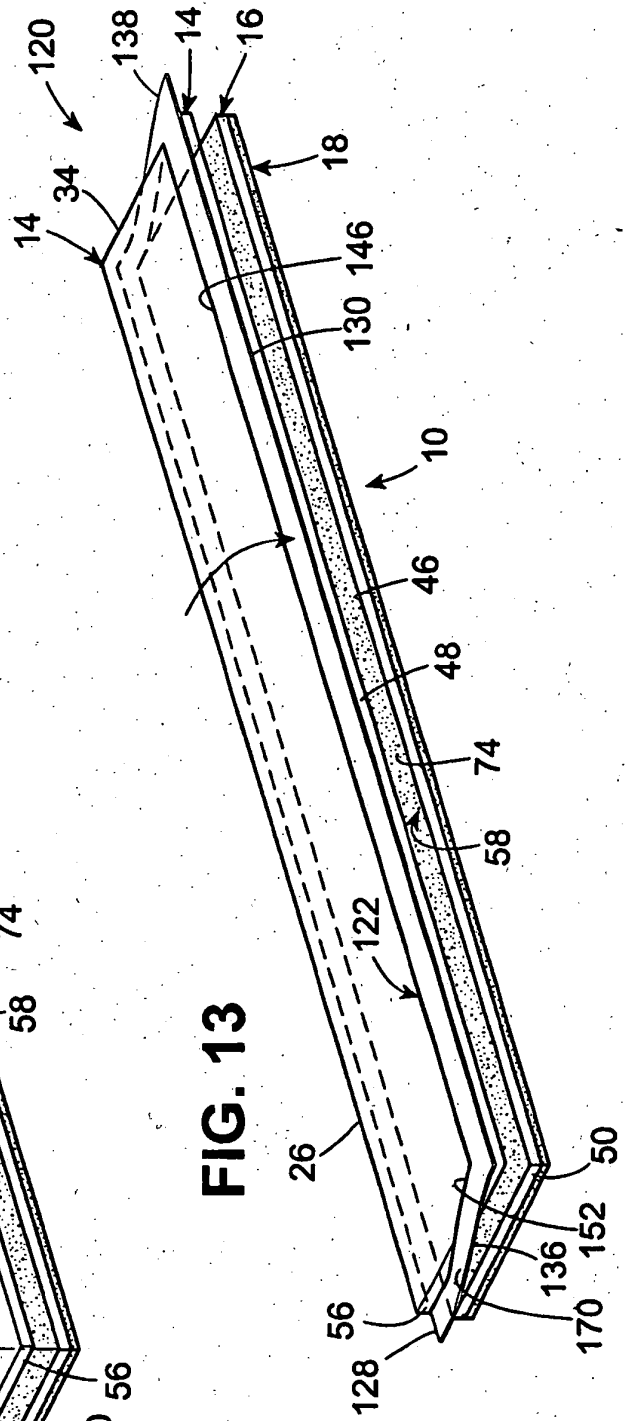

FIG. 13

FIG. 14

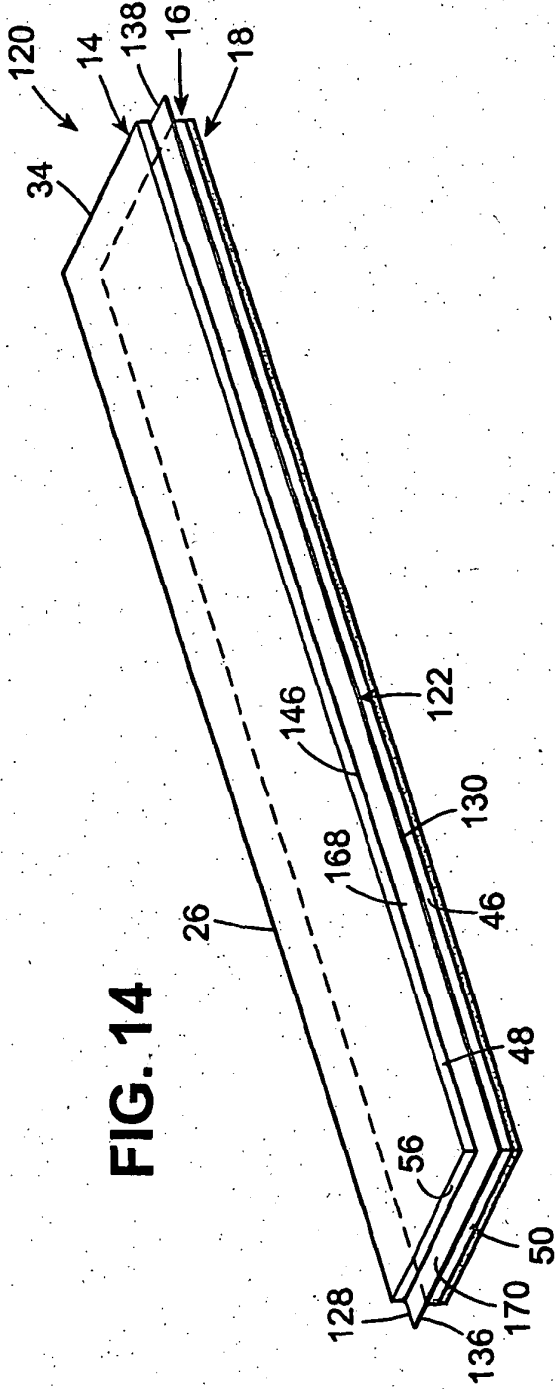

FIG. 15

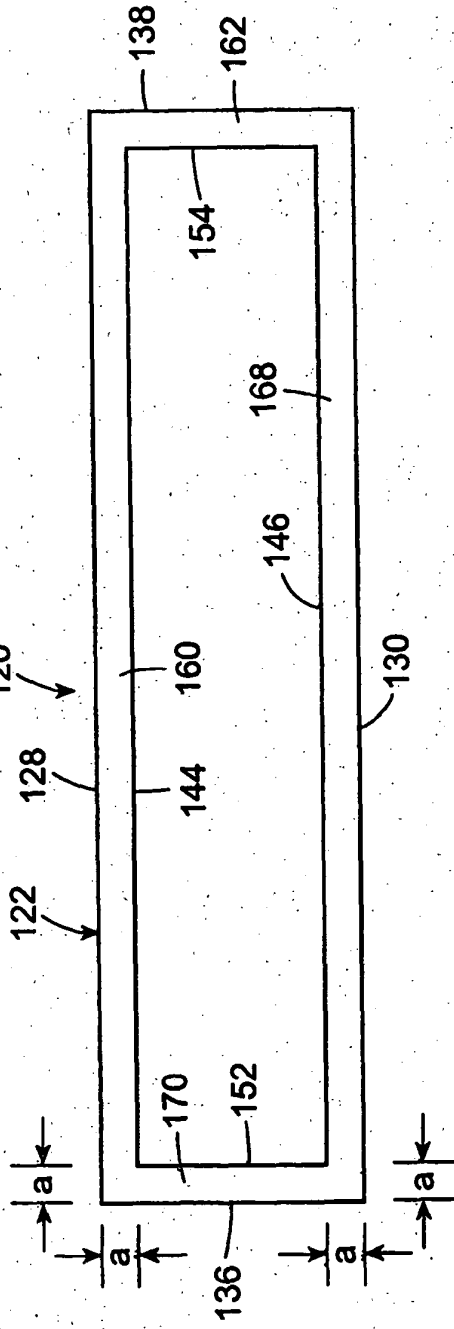
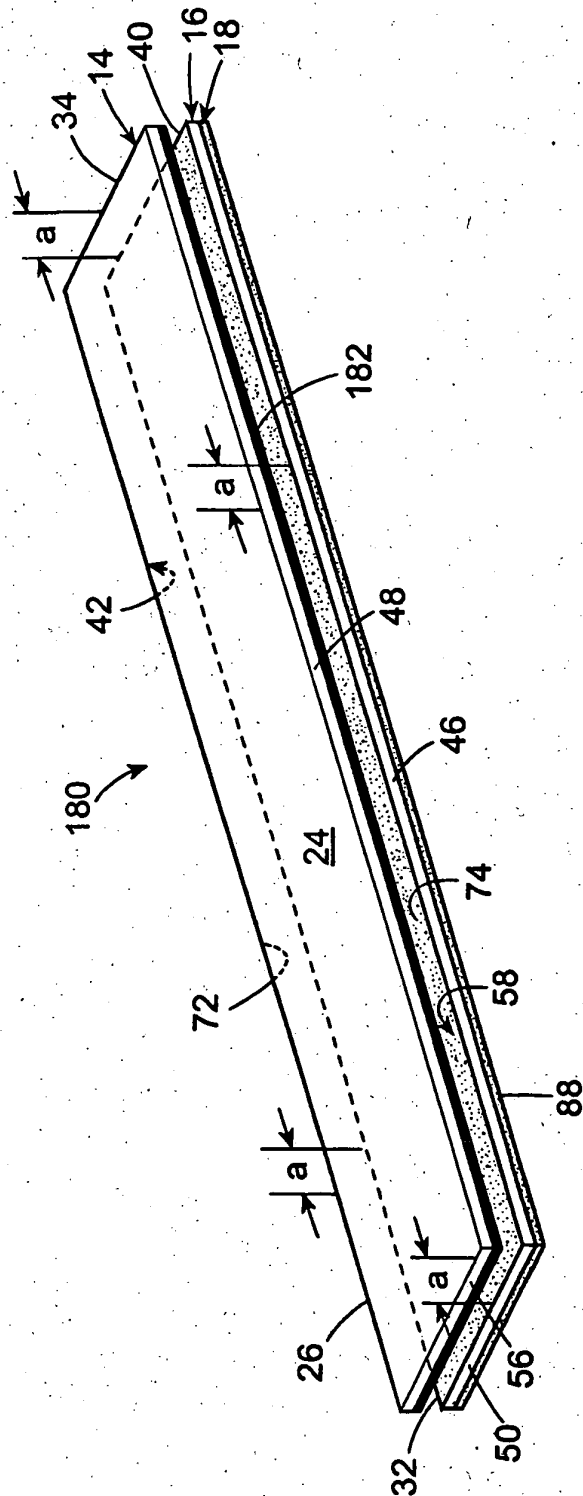

FIG. 16



REFERENCES CITED IN THE DESCRIPTION

This list of references cited by the applicant is for the reader's convenience only. It does not form part of the European patent document. Even though great care has been taken in compiling the references, errors or omissions cannot be excluded and the EPO disclaims all liability in this regard.

Patent documents cited in the description

- US 1978075 A [0002]
- US 2914815 A [0003]
- US 3554850 A [0004]
- DE 20108723 U1 [0005] [0006]
- DE 1914705 A1 [0006]
- DE 3031036 [0006]